

PARTS & HARDWARE INCLUDED: Do not remove components from cartons prior to assembly. Use the packing list to locate components. Keep hardware kits in labeled packaging until ready to use.

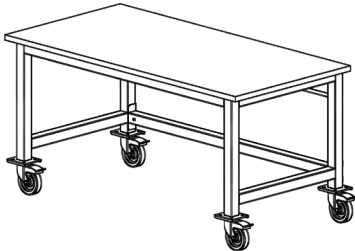

| COMPONENTS | KIT-81 | KIT-21 |
|------------------|-------------------------|---------------------------|
| Worksurface (1) | 5/16" Flat Washer (8) | 5/16" Flat Washer (4/5) |
| Frame (1) | 5/16-18 x 3/4" HHCS (8) | 5/16-18 x 3/4" HHCS (4/5) |
| Swaybrace (1) | | |
| Leg Sections (2) | | |
| Swaybar (1) | | |
| Casters (4) | | |
| | KIT-38 | KIT-84 |
| | 5/16-18 Flange Nut (16) | Z Clips (2) |
| | 5/16-18 x 5/8 HHCS (16) | Flat Clips (4) |
| | 5/16" Flat Washers (16) | 1/4" Flat Washers (2) |
| | | 1/4-20 x 3/4" RHMS (6) |

ASSEMBLY TIPS

- Lay top upside down before you begin assembly of the Frame & Legs. Pay attention to the orientation of the Top (rear inserts are closer to the edge).
- Front of Frame bears the Workplace nameplate.
- Hand-tighten all hardware until specified otherwise.
- Two people are required to turn the assembly workstation right-side-up.

ADJUSTING THE WORKHEIGHT

- Legs are typically set at 34"H and adjust in 1-1/2" increments.
- Remove the hardware from above and below the horizontal crossmember and adjust the leg extender. Replace hardware & tighten securely.

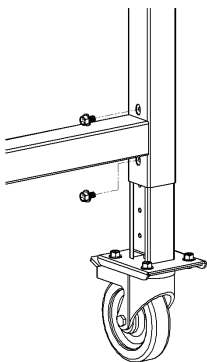

- 1 Position Frame flush to the rear edge of Worksurface. Fasten Leg Sections to Frame using KIT-81.
- 2 Fasten Swaybrace to rear of Leg Sections using KIT-21.
- 3 Remove & discard hardware from the rear base of Leg Sections; use KIT-21 to mount the Swaybar to Leg Sections.
- 4 Attach Casters to base of Leg Sections using KIT-38. Tighten hardware

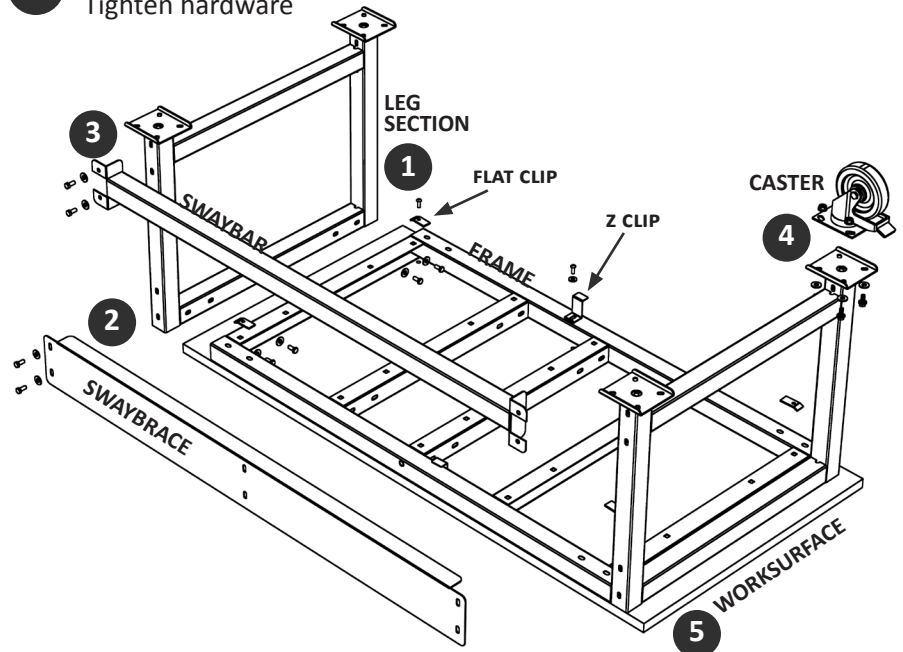

- 5 Fasten framework to Worksurface using KIT-84, note that Z clips are used in center and flat clips on ends.

NOTE: Make sure components are properly aligned.

