

PARTS & HARDWARE INCLUDED: Do not remove components from cartons prior to assembly. Use the packing list to locate components. Keep hardware kits in labeled packaging until ready to use.

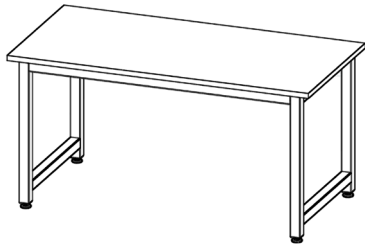

COMPONENTS	KIT-81	KIT-21
Worksurface (1)	5/16" Flat Washer (8)	5/16" Flat Washer (4/5)
Frame (1)	5/16-18 x 3/4" HHCS (8)	5/16-18 x 3/4" HHCS (4/5)
Swaybrace (1)		
Leg Sections (2)		
	KIT-84	
	Z Clips (2)	
	Flat Clips (4)	
	1/4" Flat Washers (2)	
	1/4-20 x 3/4" RHMS (6)	

ASSEMBLY TIPS

- Lay top upside down before you begin assembly of the Frame & Legs. Pay attention to the orientation of the Top (rear inserts are closer to the edge).
- Front of Frame bears the Workplace nameplate.
- Hand-tighten all hardware until specified otherwise.
- Two people are required to turn the assembly workstation right-side-up.

ADJUSTING THE WORKHEIGHT

- Legs are typically set at 34"H and adjust in 1-1/2" increments.
- Remove the hardware from above and below the horizontal crossmember and adjust the leg extender. Replace hardware & tighten securely.

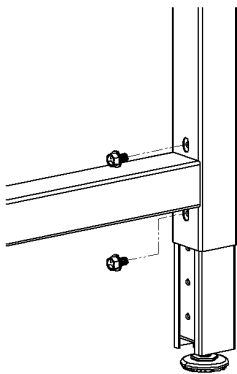

- 1 Position Frame flush to the rear edge of Worksurface. Fasten Leg Sections to Frame using KIT-81.

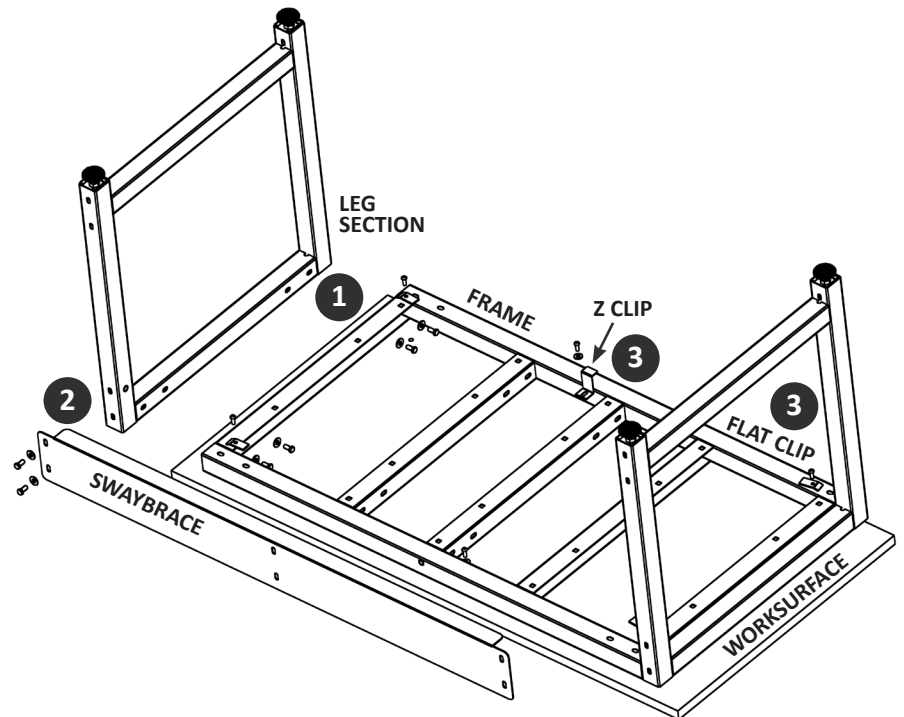

- 2 Fasten Swaybrace to rear of Leg Sections using KIT-21. Tighten hardware.

- 3 Fasten framework to the Worksurface using KIT-84, note that Z clips are used in center and flat clips on ends.

NOTE: Make sure components are properly aligned.

