

CONSTRUCTION DETAILS

- Fabricated with 2" x 2", square 18-gauge furniture grade steel tubing
- Full-perimeter frame provides support of worksurface – eliminating sagging or warpage
- Integrated brackets in frame allows for easy addition of drawers & storage at any time
- Mobile legs are manually adjustable in 1.5" increments
- Fully lockable 5" Total-Lock Casters (see Quick-Ship Accessories for additional caster selection)

COMPONENTS

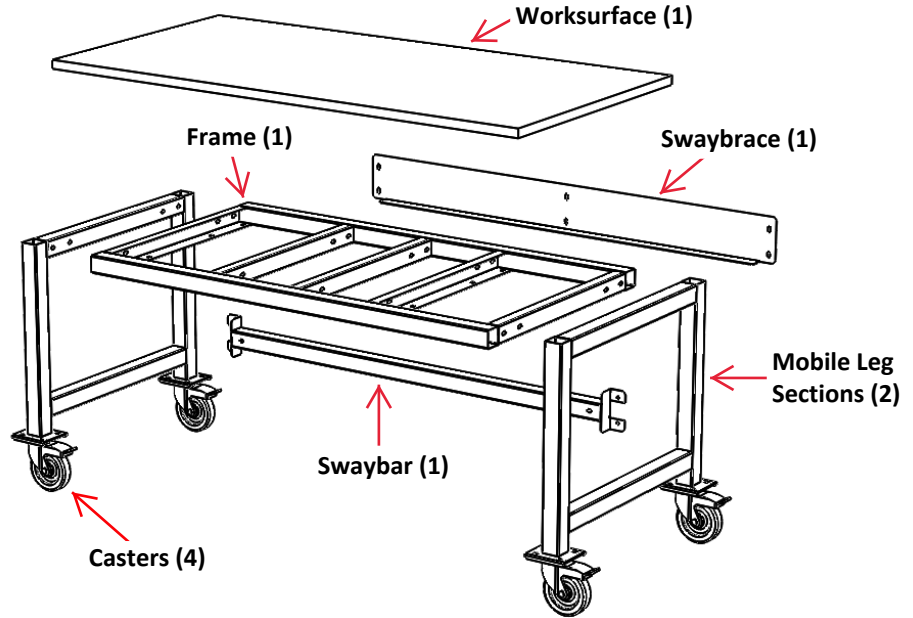

WORKSTATION SIZES & OPTIONS

Mobile Standard Workstation Sizes			
Model #	Depth	Length	Height
A4531M304830X	30"	48"	30-37.5"
A4531M306030X	30"	60"	30-37.5"
A4531M307230X	30"	72"	30-37.5"
A4531M367230X	36"	72"	30-37.5"

Optional Undertable Shelf					
Model #	Depth	Length	Model #	Depth	Length
N3020	12"	48"	N3034	18"	48"
N3021	12"	60"	N3035	18"	60"
N3022	12"	72"	N3036	18"	72"
3016	Brackets - Mounting to Mobile Leg Sections				

WORKSURFACES

LAMINATE
Square or Rounded Front Edge - 1" thick

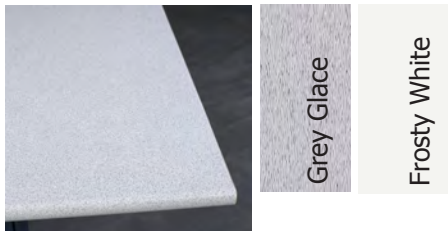

PHENOLIC RESIN
Black - 1" thick



BUTCHER BLOCK
Maple - 1-3/4" thick

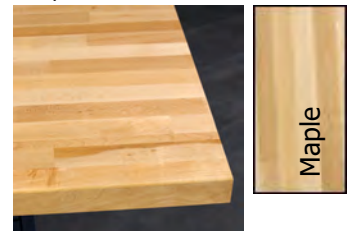

METAL PAINT COLORS



Contact a Design Specialist
603-622-3727