

CONSTRUCTION DETAILS

- Fabricated with 2" x 2", square 18-gauge furniture grade steel tubing
- Full-perimeter frame provides support of worksurface – eliminating sagging or warpage
- Legs are manually adjustable in 1.5" increments
- Fully lockable 5" Total-Lock Casters (see *Quick-Ship Accessories* for additional caster selection)

COMPONENTS

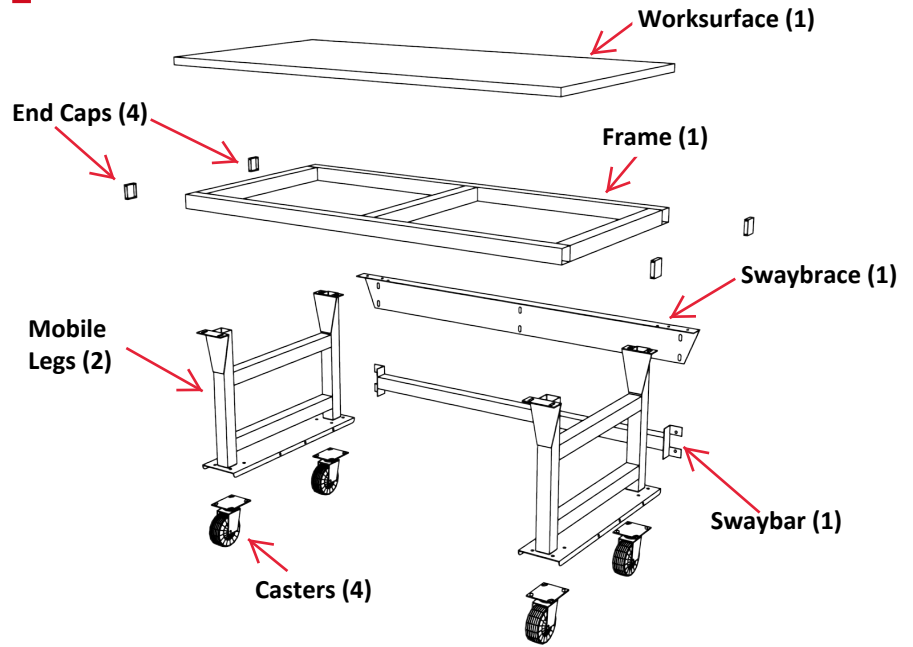

WORKSTATION SIZES & OPTIONS

Mobile Heavy-Duty Workstation Sizes			
Model #	Depth	Length	Height
A1019M304830X	30"	48"	30-37.5"
A1019M306030X	30"	60"	30-37.5"
A1019M307230X	30"	72"	30-37.5"
A1019M67230X	36"	72"	30-37.5"

Optional Undertable Shelf					
Model #	Depth	Length	Model #	Depth	Length
N3020	12"	48"	N3034	18"	48"
N3021	12"	60"	N3035	18"	60"
N3022	12"	72"	N3036	18"	72"
1250	12" Mobile Plates		1251	18" Mobile Plates	

WORKSURFACES

LAMINATE
Square or Rounded Front Edge - 1" thick

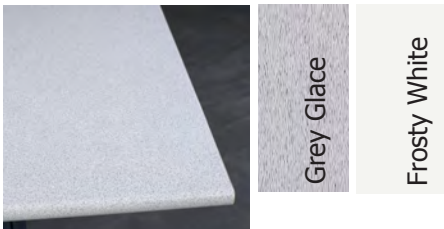

PHENOLIC RESIN
Black - 1" thick



BUTCHER BLOCK
Maple - 1-3/4" thick



METAL PAINT COLORS



Contact a Design Specialist
603-622-3727