

Selecting the appropriate furnishings for assembly processes is pivotal in optimizing productivity, as it grants operators the necessary workspace for efficient and exemplary performance.

Our adept design team comprehends the intricacies of your working environment, having collaborated with numerous prominent industrial, research, educational, and government facilities. We specialize in curating workstations that encompass the ideal combination of features, options, and accessories tailored to meet the unique demands of your tasks.

The Workplace[®] product line, known for its versatility, offers a myriad of layout possibilities, each meticulously crafted to fulfill specific requirements. These designs not only establish a robust foundation for a lifetime of reliable service but also boast adaptability, ensuring they can be easily retrofitted to accommodate evolving needs in the future.



Ready to get started? We Are.

Conceptual drawings, and detailed cost quotes are provided on a no-obligation basis. Visit our website or contact a Design Specialist today for more details.

workplacenh.com
sales@workplacenh.com
800.258.9700



Assembly Operation | MF-058



Several add-on accessories were selected for this assembly table, including a light suspension system, adjustable overtable shelf with slope option; Mounting rails with bins; 15-amp powerstrip; and double-drawer storage unit.

Assembly Station | MF-011

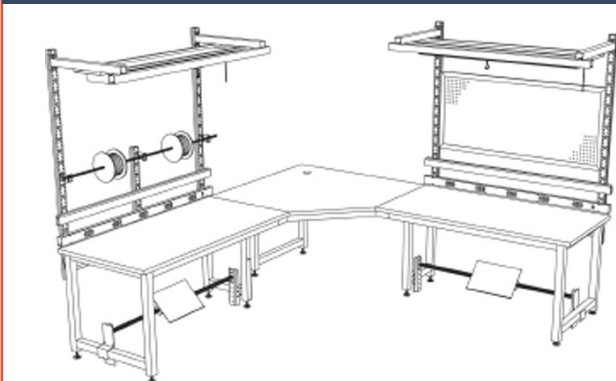

A Series 5300 Quad work center was selected for this assembly application. With dimensions of 9' x 9', the unit includes a variety of add-on accessories selected with specific work tasks and operator comfort in mind.

Final Assembly | MF-013

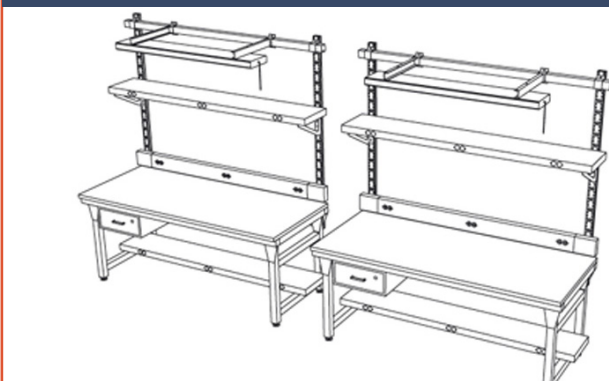

Individual Series 1000 tables were selected for this Final Assembly application, as opposed to an in-line row of tables. This would provide quick and easy re-configuration of the department's workflow. Frequent changes in product assembly processes require revamping of the assembly area, a critical element in maintaining product flow efficiencies. Adjustable Workplace[®] accessories help to maintain such efficiencies.

Mobile Assembly Unit | MF-014



Another version of a mobile assembly unit, this Series 4500 mobile table is equipped with all of the features needed to aid in the assembly process. Note that overtable shelves may be specified with or without 20-amp duplex outlets to provide needed overtable power.

Assembly Bench | MF-015

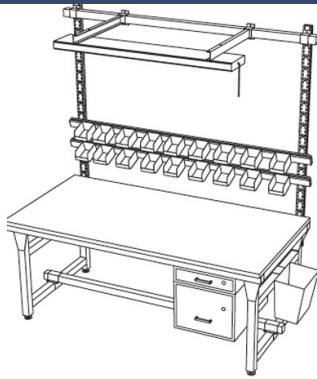

Small parts storage and organization are handled with two mounting rails, which can accommodate plastic parts bins of various sizes. Lighting is supplied with the light suspension system, which provides vertical adjustment along double Standard Uprights.

Assembly Station | MF-016

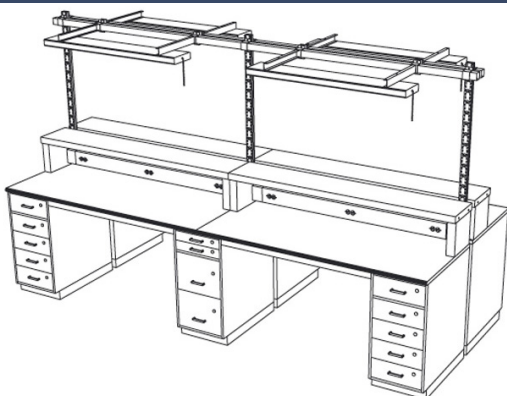

This four-person assembly station was configured with two Series 7000 Technician Station in-line rows, positioned back-to-back. Fixed riser shelf assemblies, 20-amp wiretroughs, and light suspension systems complete the station.

Final Assembly | MF-017

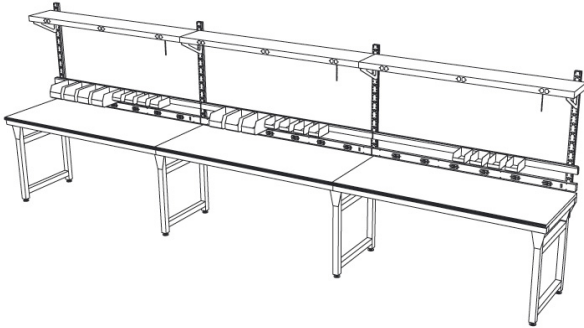

Three Series 1000 tables form an in-line row for this facility's Final Assembly operation. Post-formed tops were chosen for employee comfort, and parts bins are located on mounting rails, within easy reach. Adjustable overtable shelves may be positioned at any height along length of vertical double Standard Uprights; Light fixtures are mounted beneath each shelf.

Electronics Assembly Unit | MF-019



A post-formed worksurface with cut-outs for cabling, tops this Series 1000 table. The 30"D x 72"L unit is also equipped with an adjustable overtable shelf, a CPU caddy, storage drawer, and a backstop. These and other accessories may be added to the table at any time.

Assembly Area | MF-020

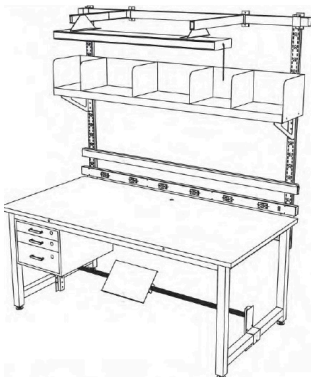

Documentation is efficiently stored overtably on an adjustable divider shelf, on this assembly area station. Storage, footrest, power, and a light source complete the unit.

Assembly Dept. | MF-021

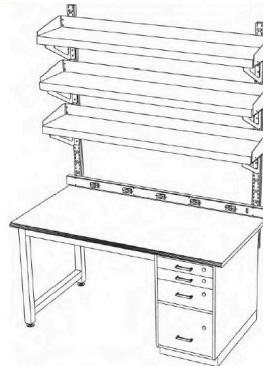

Storage is plentiful with this Assembly configuration. A Series 7400 Cabinet-to-Leg Technician Station provides drawer space, in addition to the equipment storage area furnished by the three adjustable overtable shelves.