

Workstations in the medical field are equipped with features that prioritize patient care, clinical documentation, efficient communication, and/or device manufacturing.

Our adept design team comprehends the intricacies of your working environment, having collaborated with numerous prominent industrial, research, educational, and government facilities. We specialize in curating workstations that encompass the ideal combination of features, options, and accessories tailored to meet the unique demands of your tasks.

The Workplace[®] product line, known for its versatility, offers a myriad of layout possibilities, each meticulously crafted to fulfill specific requirements. These designs not only establish a robust foundation for a lifetime of reliable service but also boast adaptability, ensuring they can be easily retrofitted to accommodate evolving needs in the future.

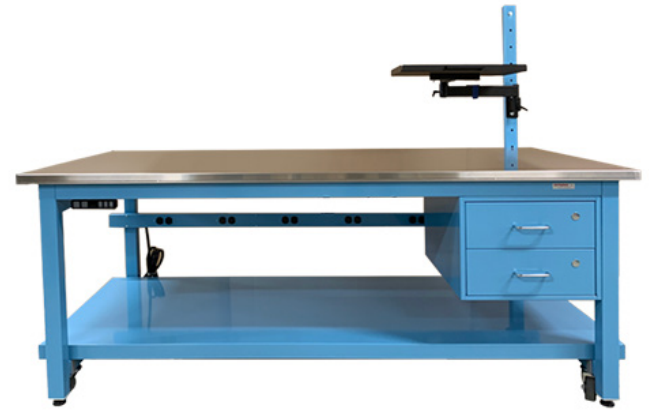

Ready to get started? We Are.

Conceptual drawings, and detailed cost quotes are provided on a no-obligation basis. Visit our website or contact a Design Specialist today for more details.

workplacenh.com
sales@workplacenh.com
800.258.9700



Donor Prep Table | LD-062



A Series 4500 Mobile Table serves as a mobile donor prep table. Accessories include double Standard Uprights, 15-amp powerstrip, double articulating monitor arms (For flat screens), an adjustable overtable shelf with back end stops, a keyboard tray and a CPU caddy.

Mobile Monitor Table | LD-031

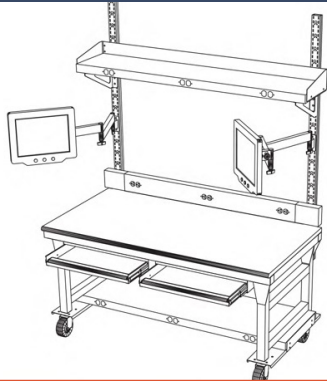

Series 4500 Mobile tables have been customized with the additional of wing units in this bi-level configuration. Optional accessories include double Standard Uprights, light suspension system, flat screen articulating arm, document holder, and keyboard tray.

Testing Station | LD-073

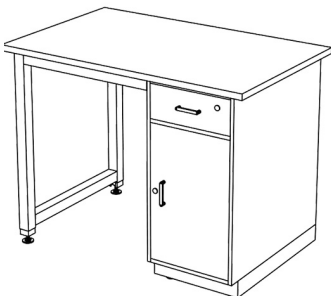

Chosen for use as a test station, this Series 7400 Technician unit provides a convenient standing-height work area with a spacious worksurface, along with undertable, lockable storage space.

Data Collection | LD-074

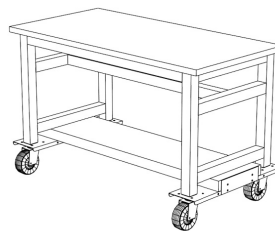

A 4500 Mobile table was modified to meet the demands of a blood bank with a need for a lab paperwork processing unit. The undertable shelf and horizontal cross-member are located at the unit's center to allow access from either side of the table.

Uniform Blood Labeling Station | LD-067

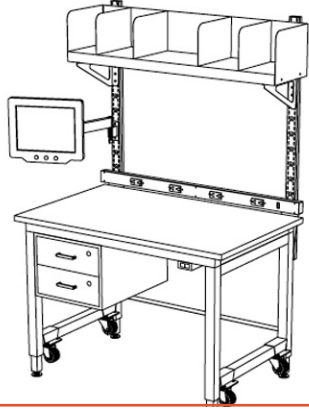

A Series 5500 Electric table with mobile option is an ideal ergonomic solution, with push button height adjustability and easy portability. Double Standard Uprights support an adjustable divider shelf, an articulating monitor arm, and powerstrip. A drawer case serves as small parts storage.

Hematology | LD-041



A combination of standard and customized components make up this mobile station. A customized "bottle holder" is mounted to the left, and a center storage shelf and pull-out shelf are mounted between the two cabinets.

Data Collection | LD-074



A combination of standard and customized components make up this mobile station. A customized "bottle holder" is mounted to the left, and a center storage shelf and pull-out shelf are mounted between the two cabinets.

Medical R&D | MF-007



A 24"Dx72"L Series 1000 table is outfitted with a 15-amp powerstrip and two adjustable overtable shelves.

Medical R&D | MF-008

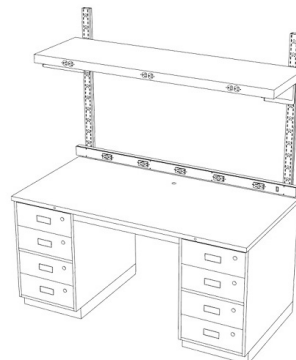

A Series 7000 Cabinet-to-Cabinet Technician Station is configured with a Conductive Top with flush-mount grounding system, a 15-amp powerstrip, and an adjustable overtable shelf with also includes 20-amp duplex outlets.

Mobile Instrument Table | LD-030



Series 6700 Mobile Instrument Table shown in 30"x60" size, with post frame plastic laminate top, and optional Model N3115 drawer case. Additional sizes, tops, and options are available.

Hematology Table | LD-040

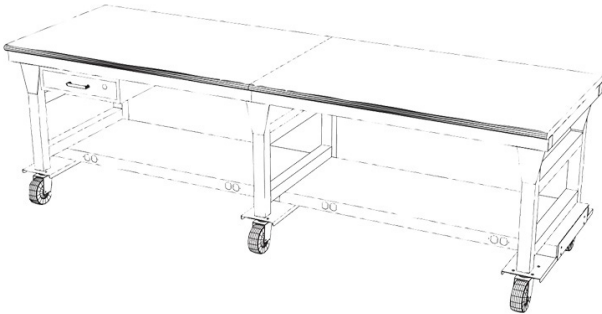

Two Series 1000 Mobile Tables are configured in-line for this Hematology system application. A single intermediate leg section is used to join two table systems together. An optional Model N3109 drawer case is mounted at the left end of this unit.

Health Lab Station | LD-043



This Series Mobile Instrument Table is 30"Dx60"L and was specified with a 12"Dx24"H fixed riser shelf assembly with back and end stops, a keyboard tray, and Model N3115 drawer case. Plastic top features a T-mold edging.

Mobile Instrument Table | LD-030



Series 6700 Mobile Instrument Table shown in 30"x60" size, with post frame plastic laminate top, and optional Model N3115 drawer case. Additional sizes, tops, and options are available.

Hematology Table | LD-040

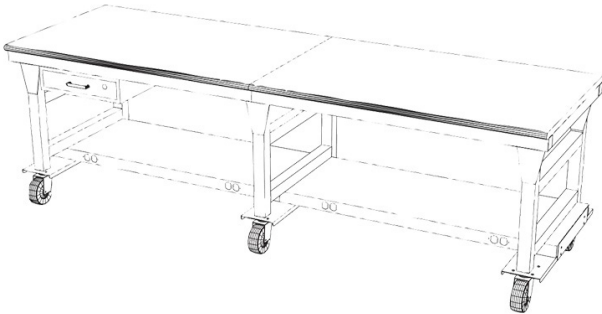

Two Series 1000 Mobile Tables are configured in-line for this Hematology system application. A single intermediate leg section is used to join two table systems together. An optional Model N3109 drawer case is mounted at the left end of this unit.

Health Lab Station | LD-043



This Series Mobile Instrument Table is 30"Dx60"L and was specified with a 12"Dx24"H fixed riser shelf assembly with back and end stops, a keyboard tray, and Model N3115 drawer case. Plastic top features a T-mold edging.