

PARTS & HARDWARE INCLUDED: Do not remove components from cartons prior to assembly. Use the packing list to locate components. Keep hardware kits in labeled packaging until ready to use.

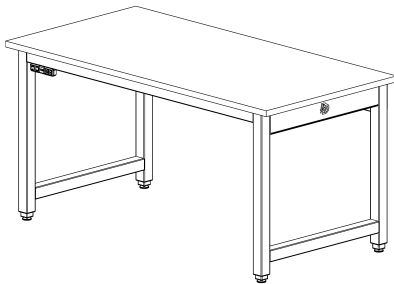

COMPONENTS	KIT-81	KIT-21
Worksurface (1)	5/16" Flat Washer (8)	5/16" Flat Washer (4/5)
Frame (1)	5/16-18 x 3/4" HHCS (8)	5/16-18 x 3/4" HHCS (4/5)
Swaybrace (1)		
Direct Drive Leg Sections (2)		
Control Kit* (1)		
	KIT-84	
	Z Clips (2)	
	Flat Clips (4)	
	1/4" Flat Washers (2)	
	1/4-20 x 3/4" RHMS (6)	

*See pg. 2 for contents

ASSEMBLY TIPS

- Lay top upside down before you begin assembly of the Frame & Legs. Pay attention to the orientation of the Top (rear inserts are closer to the edge).
- Front of Frame bears the Workplace nameplate.
- Hand-tighten all hardware until specified otherwise.
- Two people are required to turn the assembly workstation right-side-up.

NOTE: Make sure components are properly aligned.



- 1 Position Frame flush to the rear edge of Worksurface. Fasten Leg Sections to Frame using KIT-81.

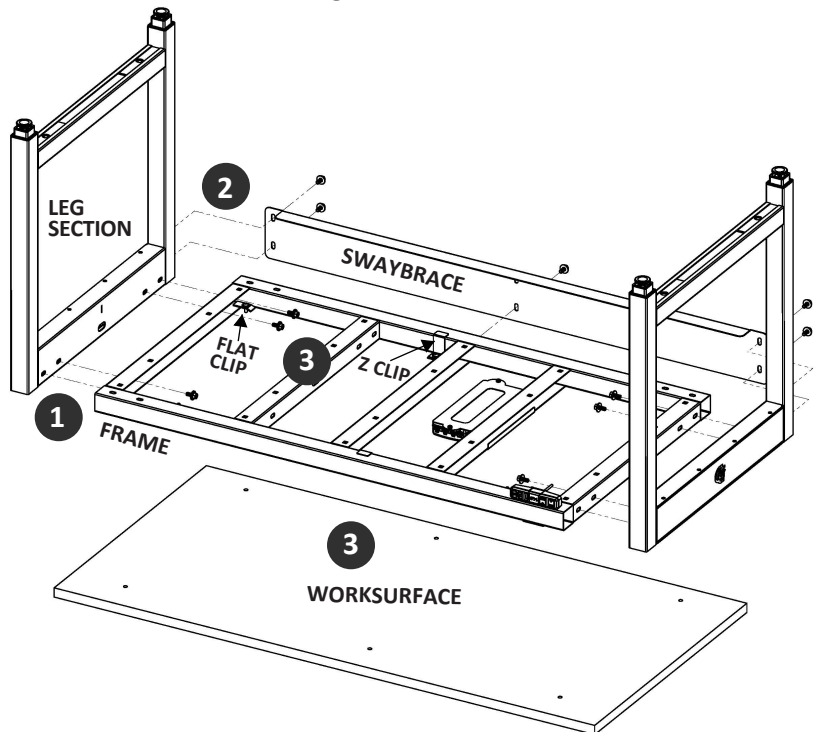

- 2 Fasten Swaybrace to rear of Leg Sections using KIT-21. Tighten hardware.



Continue to page 2 for Direct Drive Controller & Switch Mounting Instructions before moving onto step 3.

- 3

Fasten framework to the Worksurface using KIT-84, note that Z clips are used in center and flat clip on each end. KIT-18 will also be supplied with phenolic resin worksurfaces.



Continue to page 2 for instructions to synchronize the Direct Drive Workstation.

ASSEMBLY NOTES: Follow steps 1 and 2 of “Direct Drive Workstation Frame Assembly Instructions” before installing the controller and switch.

ASSEMBLY TIPS

- Continue assembly with the worksurface & frame upside down.
- Hardware isn't needed to mount the controller assembly or switch.
- Two people are required to turn the assembled workstation over once assembly is completed.

1. Position Controller Box and Switch at desired location on framework (brackets will tuck underneath the frame and hook on the crossbars).
2. Thread power cords from leg sections and switch, through the cutouts in frame channels. Use wire management clips and cable ties to hold cords in place.
3. Plug switch into control box port H. For 2 leg tables plug legs into control box ports M1 & M2. For 3 leg tables, plug legs into control box ports M1, M2, & M3. Plug power cord into control box port AC.

START-UP-02:

- Direct Drive Controller Assembly (1)
- Direct Drive Switch Controller (1)
- Small Cable Ties (3)
- Power Cord 13' (1)
- Wire Management Clips (3)

START-UP-03

- For Tables >72L or with 3 Legs
- Extension Cord 4' - Motor (2)
- Extension Cord 4' - Switch (1)
- Small Cable Ties (3)
- Wire Management Clips (3)

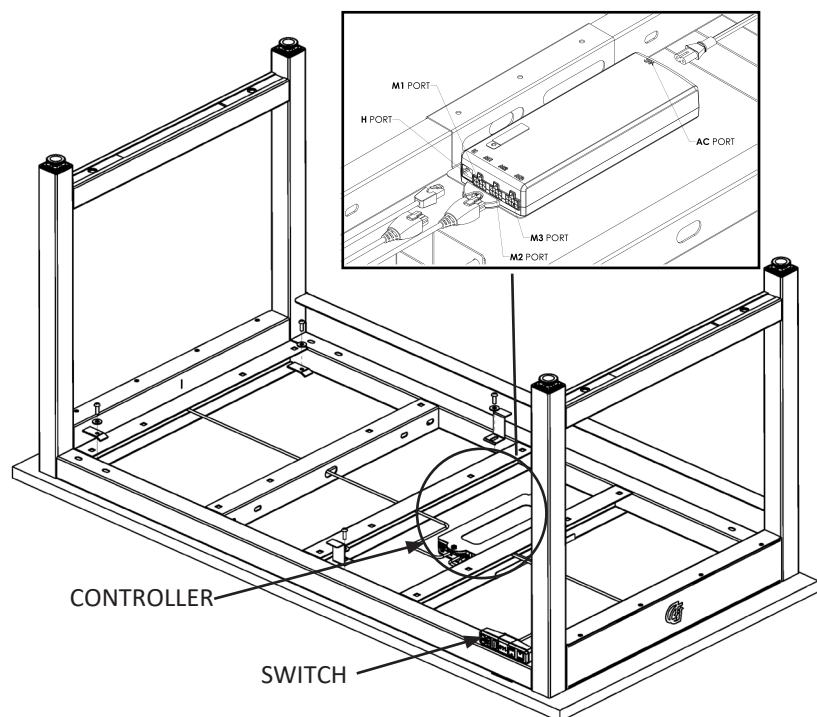

NOTE: If table is >72L or has 3 legs, use the Extension Cords in START-UP-03 to connect cords from Leg Sections & Switch to Controller Box.



To fasten the Worksurface, follow step 3 of “Direct Drive Workstation frame Assembly Instructions.” Place the workstation right side up and move onto the synchronization process below.

SYNCHRONIZING THE DIRECT DRIVE™ WORKSTATION

Simultaneously press and hold the up and down buttons on switch for 3 seconds.

Keep holding both buttons until legs are in the lowest position and control box makes a beep sound.

After you hear the beep release the buttons.

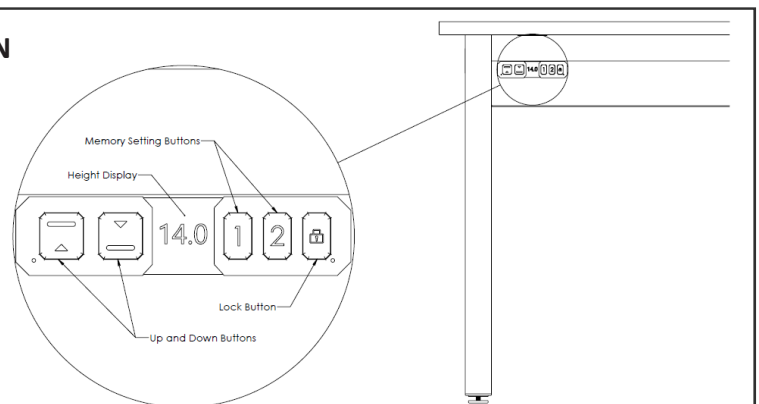



ADJUSTING THE HEIGHT

Press ▲ or ▼ button until the workstation reaches the preferred height.

SETTING THE MEMORIZED POSITION

The Direct Drive Controller supports a maximum of 2 memory positions.



1. Adjust the workstation to the desired height.
2. Press the preferred memory button (1 or 2) with either ▲ or ▼ for 2 seconds. When the display shows P1 or P2, the position is memorized.
3. Press and hold button 1 or 2 to move the workstation to the memorized position.

LOCK/UNLOCK

Lock: Press the "lock" button for one second, then the image will show on the display to indicate the lock was completed successfully (see below).



Unlock: Hold the "lock" button for 3 seconds to unlock the control.