

Configurable Workstations & Accessories



Select the accessories

to customize your **workplace** workstations

Storage Drawers

FEATURES:

- Equipped with all steel ball-bearing drawer slides for increased precision movement and minimal sideplay. Wire pull handles of solid brass with polished chrome finish.
- All storage drawers (rated at 70 lbs max) equipped with 100% full-extension slides to provide maximum utility of valuable storage space.
- Optional drawer locks keyed to your specifications (all alike, all different, or in specified sets). Drawers ordered without locks have chromed metal plugs to allow installation of locks at a later date.
- Drawer Cases may be tiered beneath each other, on a single set of Drawer Brackets.

ORDERING INFORMATION:

- On Heavy-Duty (1000) and Lab (6600) Tables: Order one pair of Drawer Brackets per Drawer Case or per set of tiered Cases (see below).
- Brackets are not required for Standard, Packing & Shipping, Corner, Motorized or Instrument Workstations.



HI-TECH MODEL NO.	SIZE/DESCRIPTION
N3109	Drawer: 2-13/16H x 13-3/4W x 20-1/2L Case: 4-1/4H x 16-3/8W x 22-1/2L
N3110	Drawer: 5-3/4H x 13-3/4W x 20-1/2L Case: 7-3/16H x 16-3/8W x 22-1/2L
N3111	Drawer: 11-5/8H x 13-3/4W x 20-1/2L Case: 13H x 16-3/8W x 22-1/2L
N3111-FD	N3111 with File Drawer option. See page 42 for complete information.
N3113	Two 3109 Drawers in 3110 Case
N3114	Two 3110 Drawers in 3111 Case
N3115	One 3110/Two 3109 Drawers in 3111 Case
N3116	Four 3109 Drawers in 3111 Case
P2401A	Drawer Lock with 2 keys
P2409A	Master Key



Standard Drawer Bracket



Heavy Duty Drawer Bracket

Drawer Brackets

ORDERING INFORMATION:

- Standard Brackets are recommended for light to medium weight loads. Specify Heavy-Duty Bracket for heavier weight loads, or when multiple Drawer Cases are tiered.
- For Lab units: Order one pair Model #3120 Brackets.

STANDARD BRACKETS	HEAVY-DUTY BRACKET	TABLE DEPTH
3121	3121HD	24"
3122	3122HD	30"
3123	3123HD	36"
3120	For Lab (6600) Tables (pair)	



Pull-Out Shelf (Work Tray)

FEATURES:

- Shelf extends from case as a flat work surface or may be inverted for use as a 1-1/2" deep work tray.
- Drawer Cases may be tiered beneath the Pull-Out Shelf.
- Equipped with all steel ball-bearing drawer slides for increased precision movement and minimal sideplay. Wire pull handle of solid brass with polished chrome finish.
- Dimensions:
O.D. 16-3/8"W x 22-1/2"L x 3-1/8"H
I.D. 13-1/2"W x 20"L x 1-1/2"D

ORDERING INSTRUCTIONS:

- May be specified for use on all workstation styles.
- Please specify one pair Drawer Brackets (p. 60) to mount Pull-out Shelf to Heavy-Duty and Cabinet Table Frames.

MODEL NUMBER	DESCRIPTION
N3142	Pull-Out Shelf (Work Tray)



Drawer Tray

FEATURES:

- Excellent for storage of small parts, pencils, clips, etc.
- All-metal Drawer Tray slides along top edges of drawer to provide view of contents stored below.
- Increases valuable storage space; protects small items from damage.

ORDERING INFORMATION

- Available in #0001 Tan finish only.

MODEL NUMBER	DESCRIPTION
3128-0001	8" wide x 1" deep



Drawer Partitions

- Drawer Partitions are designed for use in small or medium Workplace® drawers.
- Starter Kits include:
Partition Framework
(1 rear/2 side frames)
3 Horizontal Channels
4 Small Vertical Dividers 3-3/4"L
4 Large Vertical Dividers 5-3/4"L
2 Horizontal Dividers 16"L.

MODEL NUMBER	DESCRIPTION
3510	Starter Kit for 20"D Drawers
3511	Starter Kit for 26"D Drawers

Add-On Kits:

3515-5	Horizontal Dividers (set of 5)
3516-10	Small Vertical Dividers (set of 10)
3517-10	Large Vertical Dividers (set of 10)



Drawer Mats

- Keeps tools, small items, and equipment from sliding during opening and closing of drawers.
- 1/8" thick ribbed rubber matting.

MODEL NUMBER	DESCRIPTION
3520-5	Package of 5 Drawer Mats for 20-1/2"D drawers
3521-5	Package of 5 Drawer Mats for 26-1/2"D drawers



Personal Locker

FEATURES:

- Ideal for small hand tools, parts, or personal belongings.
- Locker suspends from open style Heavy-Duty Leg Section with upper crossmember, on outside or inside of Leg Section. Unit may also be suspended from Frame on Drawer Brackets.
- Includes one adjustable shelf and one lock with two keys. Master key available as an option. O.D. of unit is 10"W x 14"D x 18"H.
- Door is equipped with left-hand hinge.

ORDERING INFORMATION:

- To suspend from upper crossbar of Heavy-Duty open-style Leg Section, please specify one Model #30018 Bracket.
- To mount to Heavy-Duty or Standard Frame, please order one pair of Standard Drawer Brackets (p. 60).

MODEL NUMBER	DESCRIPTION
N3107LH	Personal Locker
30018	Leg Bracket

accessories



Single Monitor Floating Arm

FEATURES:

- Includes bracket to mount to Solid Upright (sold separately).
- Accepts VESA standard 75mm or 100mm flat-screen monitors.
- Arm extends 24" and adjusts vertically 16".
- Monitor can pivot, tilt and rotate 360°.

MODEL NUMBER	DESCRIPTION
3910	Single Monitor Floating Arm



Monitor Keyboard Floating Arm

FEATURES:

- Includes bracket to mount to Solid Upright (sold separately).
- Accepts VESA standard 75mm or 100mm flat-screen monitors.
- Arm extends 17.5"; adjusts vertically 14"
- Monitor can pivot, tilt and rotate 360°
- Keyboard tray: 8"D x 27"W (with wrist rest).

MODEL NUMBER	DESCRIPTION
3920	Monitor Keyboard Floating Arm



Dual Monitor Floating Arm

FEATURES:

- Includes bracket to mount to Solid Upright (sold separately).
- Accepts VESA standard 75mm or 100mm flat-screen monitors—max screen size 24"
- Arm extends 24" and adjusts vertically 16"
- Monitors pivot, tilt, and can be stacked vertically.

MODEL NUMBER	DESCRIPTION
3930	Dual Monitor Floating Arm



Dual Flat-Screen Articulating Arm

FEATURES:

- Heavy-duty swivel arm with compact design to accommodate 2 monitors.
- Tilt feature allows monitors to be adjusted for operator comfort.
- Maximum screen size of 24" to accommodate both monitors.

MODEL NUMBER	DESCRIPTION
3575	Dual Monitor Articulating Arm
3590	Extra arm for additional extension capability



Monitor Keyboard Articulating Arm

FEATURES:

- Ideal solution to keep monitor, keyboard and mouse up off of worksurface.
- Accepts 75mm or 100mm VESA standard flat-panel monitors.
- 30 degree monitor tilt plus 30 degree independent keyboard adjustment.
- Monitor height adjustment of 4"; keyboard depth adjustment of 2".
- Arm extension of 25" (from mounting bracket to center of keyboard tray).
- Overall dimensions of keyboard tray: 8"D x 25"W.

MODEL NUMBER	DESCRIPTION
3565	Monitor Keyboard Articulating Arm
3590	Extra arm for additional extension capability

Single Monitor Articulating Arm

FEATURES:

- Mounts to Solid Upright (sold separately).
- Accepts VESA standard 75mm or 100mm flat-screen monitors. Allows monitor to be tilted or swiveled.

MODEL NUMBER	DESCRIPTION
3560	Articulating Arm for Flat Screen Monitor



Articulating Arm Extension

FEATURES:

- Provides additional 12" extension.
- Includes cable cover and rotation locking lever.

MODEL NUMBER	DESCRIPTION
3590	Extra arm for additional extension capability



Laptop Articulating Arm

FEATURES:

- Mounts to Solid Upright (sold separately).
- May be used as a flat surface, or set at 3 different angles using knurled knob spring pins.
- Overall dimensions of tray surface: 16"W x 11-3/4"H with 3/8" front lip.
- Two compression clips included for use with laptops up to 13"W.

MODEL NUMBER	DESCRIPTION
3570	Laptop Articulating Arm
3590	Extra arm for additional extension capability



Series II Panel Riser with optional Safety Shield



Series IV Panel Riser

Panel Riser Shelf Assembly

FEATURES:

- Equipped with enclosed inner panels to create a more finished appearance.
- Optional Safety Shield available on page 64.

ORDERING INFORMATION:

- Specify Assembly length to match Table Length. Please note various styles available:
- Please specify one Insulator Kit per Fixed Riser Assembly if mounted to a table with an ESD Top.
- Deduct 2" from height for clearance under Shelf.

Series I: Inner panels of vertical risers bear cutouts to accept the optional 20 Amp Powertrough.

Series II: Free of any cutouts for 20 Amp Powertrough, which cannot be installed.

Series III: Includes three 20 amp duplex outlets (on 60" & 72" lengths); two duplex on 48" length in Shelf; one duplex in left vertical riser; on/off switch and pilot light in right riser. Vertical risers bear cutouts to accept optional 20 Amp Powertrough. Requires 20-amp Power Cord.

Series IV: Same electrical features as Series III. No cutouts for optional 20 Amp Powertrough. Requires 20-Amp Power Cord.

SIZE MODEL NO.	SERIES I MODEL NO.	SERIES II MODEL NO.	SERIES III MODEL NO.	SERIES IV MODEL NO.
12"D x 12"H x 48"L	N3173-WT	N3173	N3213-WT	N3213
12"D x 12"H x 60"L	N3174-WT	N3174	N3214-WT	N3214
12"D x 12"H x 72"L	N3175-WT	N3175	N3215-WT	N3215
12"D x 18"H x 48"L	N3179-WT	N3179	N3219-WT	N3219
12"D x 18"H x 60"L	N3180-WT	N3180	N3220-WT	N3220
12"D x 18"H x 72"L	N3181-WT	N3181	N3221-WT	N3221
12"D x 24"H x 48"L	N3185-WT	N3185	N3225-WT	N3225
12"D x 24"H x 60"L	N3186-WT	N3186	N3226-WT	N3226
12"D x 24"H x 72"L	N3187-WT	N3187	N3227-WT	N3227
18"D x 12"H x 48"L	N3191-WT	N3191	N3231-WT	N3231
18"D x 12"H x 60"L	N3192-WT	N3192	N3232-WT	N3232
18"D x 12"H x 72"L	N3193-WT	N3193	N3233-WT	N3233
18"D x 18"H x 48"L	N3197-WT	N3197	N3237-WT	N3237
18"D x 18"H x 60"L	N3198-WT	N3198	N3238-WT	N3238
18"D x 18"H x 72"L	N3199-WT	N3199	N3239-WT	N3239
18"D x 24"H x 48"L	N3203-WT	N3203	N3243-WT	N3243
18"D x 24"H x 60"L	N3204-WT	N3204	N3244-WT	N3244
18"D x 24"H x 72"L	N3205-WT	N3205	N3245-WT	N3245



Model 3127 Caddy

CPU Caddy

FEATURES:

- Adjustable CPU Caddy may be hung from Heavy-Duty Leg Sections with the use of the Leg Bracket, or mounted beneath most Workplace® Frames (except Packing & Shipping Station). Model 3127 accepts vertical CPUs from 13" to 22" high and up to 8-1/4" wide.

ORDERING INFORMATION:

MODEL NUMBER	DESCRIPTION
3127	CPU Caddy
3132LB	Leg Mount Bracket
3132-24	Frame Mount Bracket - 24"D
3132-30	Frame Mount Bracket - 30"D
3132-36	Frame Mount Bracket - 36"D
3127-LB	Lower Leg Mount Bracket
3131	Frame Mount Bracket: Motorized Wkstin



Keyboard Tray

FEATURES:

- Equipped with all steel ball-bearing drawer slides.
- Built-in 2" wide full-length padded wrist rest.
- Keyboard clearance height is 2". Tray accommodates keyboard of up to 13" depth x 22" length.

ORDERING INFORMATION:

- Contact your Design Specialist for mounting options.
- Note: Table workheight must be at least 34" to accommodate Keyboard Tray.

MODEL NUMBER	DESCRIPTION
3135	Keyboard Tray

accessories



Standard Fixed Riser Assembly

FEATURES:

- Increases workstation storage space. Assembly fastens directly to worksurface.
- Fixed Riser Assemblies may be tiered to provide additional storage space.
- Interconnect Kits available to provide electrical connection between Fixed Riser Assemblies equipped with electricals and the optional 20 Amp Powertrough.

ORDERING INFORMATION:

- Please specify Fixed Riser Assembly length to match workstation length.
- To fasten to ESD Worksurface: Please order one Insulator Kit for each Fixed Riser Assembly. For tiered Fixed Riser Assemblies: Please specify one Kit-14A for each set of tiered assemblies.
- Deduct 2" from height for clearance under Shelf.
- Assemblies with duplex outlets require a 20-amp Power Cord (purchased separately).

SIZE	MODEL NUMBER WITHOUT ELECTRICS	MODEL NUMBER WITH ELECTRICS
12"D x 12"H x 48"L	3173	3213 (2)*
12"D x 12"H x 60"L	3174	3214 (3)
12"D x 12"H x 72"L	3175	3215 (3)
12"D x 18"H x 48"L	3179	3219 (2)
12"D x 18"H x 60"L	3180	3220 (3)
12"D x 18"H x 72"L	3181	3221 (3)
12"D x 24"H x 48"L	3185	3225 (2)
12"D x 24"H x 60"L	3186	3226 (3)
12"D x 24"H x 72"L	3187	3227 (3)
18"D x 12"H x 48"L	3191	3231 (2)
18"D x 12"H x 60"L	3192	3232 (3)
18"D x 12"H x 72"L	3193	3233 (3)
18"D x 18"H x 48"L	3197	3237 (2)
18"D x 18"H x 60"L	3198	3238 (3)
18"D x 18"H x 72"L	3199	3239 (3)
18"D x 24"H x 48"L	3203	3243 (2)
18"D x 24"H x 60"L	3204	3244 (3)
18"D x 24"H x 72"L	3205	3245 (3)

* Indicates quantity of duplex outlets provided

MODEL NUMBER	DESCRIPTION
Kit-89	Interconnect Kit - For 12"D x 12"H Riser Assembly to 20 Amp Powertrough.
Kit-90	Interconnect Kit - For 12"D x 18"H or 18"D x 12"H Riser Assembly to 20 Amp Powertrough.
Kit-91	Interconnect Kit - For 18"D x 18"H or 12"D x 24"H Riser Assembly to 20 Amp Powertrough.
Kit-92	Interconnect Kit - For 18"D x 24"H Riser Assembly to 20 Amp Powertrough.
Kit-66	Insulator Kit to mount 12"D Riser Assembly to ESD Top.
Kit-67	Insulator Kit to mount 18"D Riser Assembly to ESD Top.

Fixed Riser Safety Shield

FEATURES:

- Provides complete enclosure between worksurface and overtable shelf on Fixed Riser Assembly (p. 63-64).
- All-metal construction allows Safety Shield to double as a magnetic "memo board".

ORDERING INFORMATION:

- Please specify height and length to match height and length of Fixed Riser Assembly.
- Please contact factory for more information regarding use of Safety Shield with Powerstrip.

MODEL NUMBER	HEIGHT	LENGTH
3080-12	12"	48"
3080-18	18"	48"
3080-24	24"	48"
3081-12	12"	60"
3081-18	18"	60"
3081-24	24"	60"
3082-12	12"	72"
3082-18	18"	72"
3082-24	24"	72"



15/20 Amp Powerstrip

FEATURES:

- Compact 2-3/8"H x 1-3/4"D design.
- Pre-wired with 15 OR 20 Amp 125V duplex outlets and combination circuit breaker, pilot light and on/off switch.
- Includes factory-installed 9 ft. Power Cord.

ORDERING INFORMATION:

- May be specified on all table series. Specify Powerstrip length to match length of Table.
- Powerstrip may be mounted directly to the Solid Uprights (p. 68; within a Standard Fixed Riser Shelf Assembly (p. 64); or to the rear of the Leg Sections/Cabinet (may require Wiretrough Brackets sold separately on p. 66).

MODEL NUMBER	WORKSTATION LENGTH	DESCRIPTION
3848	48"L	Full-length 15A Powerstrip - 4 duplex
3849	48"L	Full-length 20A Powerstrip - 4 duplex
3860	60"L	Full-length 15A Powerstrip - 5 duplex
3860-50	60"L	Half-length 15A Powerstrip - 3 duplex
3861	60"L	Full-length 20A Powerstrip - 5 duplex
3861-50	60"L	Half-length 20A Powerstrip - 3 duplex
3872	72"L	Full-length 15A Powerstrip - 6 duplex
3872-50	72"L	Half-length 15A Powerstrip - 3 duplex
3873	72"L	Full-length 20A Powerstrip - 6 duplex
3873-50	72"L	Half-length 20A Powerstrip - 3 duplex
3840		Joining plate for 2 adjoining Powerstrips when bolting directly to Solid Uprights



Configurable Powertrough

FEATURES:

- Equipped with removable covers at each end where terminal blocks are wired into the circuit, so that primary entrance may be made from left or right of trough.
- Optional data chase may be specified.
- Standard configured outlets are UL approved 20Amp /125V grounded outlets. Unique outlet configurations may be specified.
- Powertroughs may be configured with several circuit protection features such as 20Amp circuit breaker, GFI breaker, power reset switch and others.
- Standard Powertrough dimensions are 4-5/8"H x 2"D.

Standard 20 Amp Powertrough

MODEL NUMBER	TABLE LENGTH	DESCRIPTION
3156	48"L	Powertrough with 2 Duplex Outlets
3156-3	48"L	Powertrough with 3 Duplex Outlets
3156-4	48"L	Powertrough with 4 Duplex Outlets
3157	60"L	Powertrough with 3 Duplex Outlets
3157-5	60"L	Powertrough with 5 Duplex Outlets
3157-7	60"L	Powertrough with 7 Duplex Outlets
3158	72"L	Powertrough with 3 Duplex Outlets
3158-5	72"L	Powertrough with 5 Duplex Outlets
3158-7	72"L	Powertrough with 7 Duplex Outlets
3159	48"L	Powertrough with 2 Duplex Outlets, Circuit Breaker & Pilot Light
3160	60"L	Powertrough with 3 Duplex Outlets, Circuit Breaker & Pilot Light
3161	72"L	Powertrough with 3 Duplex Outlets, Circuit Breaker & Pilot Light
3162	48"L	Powertrough with 2 Duplex Outlets and Ground Fault System
3163	60"L	Powertrough with 3 Duplex Outlets and Ground Fault System
3164	72"L	Powertrough with 3 Duplex Outlets and Ground Fault System

ORDERING INFORMATION:

- May be mounted to all workstations. Order Powertrough to match workstation length.
- Mounting brackets may vary depending on configuration.
- Requires 20Amp Power Cord (sold separately). See page 66 to order.
- In-Line Wiring Kits are available to interconnect in-line Powertroughs.

accessories

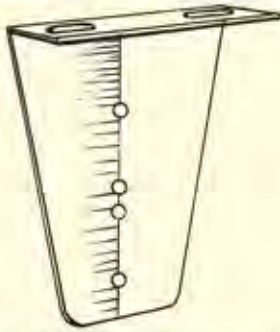

Powertrough/Powerstrip Brackets

FEATURES:

- Provides simple, convenient method of mounting Powertrough or Powerstrip to table. Brackets mount to rear of Leg Sections.

ORDERING INFORMATION:

- To mount Powertrough to a unit with Solid Uprights: Specify two Model 3167 Brackets per table, or one Bracket per Leg Section or Cabinet of an in-line row.
- To mount Wiretrough to a unit without Solid Uprights: Specify two Model 3168 Brackets per table, or one Bracket per Leg Section or Cabinet of an in-line row.
- To mount Powertrough within a Fixed Riser Assembly: Brackets are not required.
- To mount Powerstrip to a unit without Solid Uprights: Specify two Model 3168 Brackets per table, or one Bracket per Leg Section or Cabinet of an in-line row.
- 3167-01 Powertrough Brackets permit mounting of Powertrough to rear of bench (below worksurface).

MODEL NUMBER	DESCRIPTION
3167	Flat Bracket
3168	Standard Bracket
3167-01	Rear Mount Powertrough Bracket



Airtrough

FEATURES:

- Neat, compact 2"D x 2-1/4"H design.
- Equipped with brass quick disconnects.
- Inlet at rear allows quick interconnect to your air delivery system.
- Female disconnect at rear allows for efficient daisy-chaining to adjacent workstations.
- Mounts to the Solid Uprights or with the use of Powertrough Brackets (sold separately at left).
- Maximum working pressure: 125 PSI (at 73°F).

ORDERING INFORMATION:

MODEL NUMBER	DESCRIPTION
3740	For 48"L units (with 2 quick disconnects at front; 1 at rear)
3742	For 60"L units (with 3 quick disconnects at front; 1 at rear)
3744	For 72"L units (with 4 quick disconnects at front; 1 at rear)



Close-up view of inlet at rear

Power Cords

ORDERING INFORMATION:

- Please check wall receptacles where cords are to be used to make certain they match the NEMA configurations shown below. If they do not match, cords will not fit.



3060-01



3061-01

MODEL NUMBER	DESCRIPTION
3060-01	9 ft. 14 ga. 3-wire 15 amp 125V
3061-01	9 ft. 12 ga. 3-wire 20 amp 125V

* Additional cord configurations and lengths available upon request.



Light Suspension System

FEATURES:

- Positions Light Fixture (sold separately) over table to assure even light diffusion.
- May be adjusted to desired height along length of Solid Uprights.

ORDERING INFORMATION:

- Order Light Suspension size to match depth and length of Table.
- Requires Solid Uprights (sold separately on page 68).
- Light Fixtures sold separately (at right).
- For in-line use: Specify one Kit 14-B for each two abutting Light Suspension Systems.
- For Tables equipped with three Solid Uprights: Specify one #31000 bracket for each table equipped with three uprights.

MODEL NUMBER	TABLE DEPTH	TABLE LENGTH
3272	24"	48"
3273	30"	48"
3274	36"	48"
3275	24"	60"
3276	30"	60"
3277	36"	60"
3278	24"	72"
3279	30"	72"
3280	36"	72"

Kit 14-B	For adjoining in-line Light Suspension Systems.
31000	Bracket to fasten Light Suspension System to third (center) Solid Upright.



Light Suspension Tilt Kit

FEATURES:

- Provides more control over light source from Light Suspension System (sold separately at left).
- Extending horizontal channels allow Light Fixture to be moved closer to the front of the workstation if needed, while tilt action feature allows operator to position light to most beneficial setting.
- Control knobs allow easy repositioning.

ORDERING INFORMATION:

- Order one Tilt Kit per Light Suspension System.

MODEL NUMBER	DESCRIPTION
3270	Tilt Kit



Lamp Mount Bracket

FEATURES:

- Mounts to Solid Upright (sold separately).
- Screw-down bracket accepts lamp/ magnifiers with a 1/2" stud.

MODEL NUMBER	DESCRIPTION
3271	Lamp Mount Bracket



Light Fixtures

FEATURES:

- Durable Light Fixtures feature electronic ballast.
- White enamel paint finish.
- Includes factory-installed switch and 15 Amp 9' Power Cord.
- Available in 24" and 48" lengths.

ORDERING INFORMATION:

- Mounts to Light Suspension System (sold separately) or beneath Overtable or Fixed Riser Shelves.
- Choose 24" Fixture for shelf lengths less than 48".
- Light Fixtures shipped without tubes. Fluorescent or LED tubes available upon request.

MODEL NUMBER	DESCRIPTION
3058-02	48" Two-Tube Light Fixture
3057-02	24" Two-Tube Light Fixture

accessories



Multi-Adjust Footrest

FEATURES:

- Ergonomically designed to move in virtually every direction for all-day comfort.
- Spacious 18" x 12" Footpad is covered with non-slip ribbed rubber matting.
- Easy to adjust up-down, left-right, back-forward, and to any angle.

ORDERING INFORMATION:

- May be specified for use on Standard, Heavy-Duty, and Motorized Workstations, which have open-style Leg Sections. Order footrest length to match Table length.
- Please note that use of Multi-Adjust Footrest on continuous, in-line units requires staggering of horizontal members.

MODEL NUMBER	TABLE LENGTH
N3147	48"
N3148	60"
N3149	72"
3298	Extra footpad*

*Extra footpad for use on multi-person workstations:



Standard Footrest

FEATURES:

- Adjusts front-to-back along depth of Leg Section crossmembers.
- Constructed of 18 gauge 2" square furniture grade tubing. Mounting brackets supplied.

ORDERING INFORMATION:

- May be specified on Standard, Heavy-Duty, and Motorized Workstations, which have open-style Leg Sections.
- Please consult your Design Specialist for use on Cabinet Workstations or units with Panel Leg Sections.
- Please order Footrest Length to match Table length.

MODEL NUMBER	TABLE LENGTH
3147	48"
3148	60"
3149	72"



Solid Uprights

FEATURES:

- Uprights are designed to accept a variety of Workplace overtable accessories.
- Front is perforated in 3" increments. Uprights bolt directly to rear of Leg Sections.

ORDERING INFORMATION:

- Uprights may be specified for all series Workplace® Leg Sections.
- Order one upright per Leg Section
- Please note that 9" of length is required to fasten to Heavy-Duty Leg Section. Deduct 7" for other workstations.
- Uprights may be mounted to rear of Cabinet Workstations.
- If three solid uprights are specified, please order one Center Mounting Bracket per table.
- Stiffener plate recommended for use on stand-alone upright.

MODEL NUMBER	LENGTH/DESCRIPTION
3000-04	48" Solid Upright
3000-05	60" Solid Upright
3000-06	72" Solid Upright
3401	Center Standard Mounting Bracket for Heavy-Duty Wkstn
3404	Center Standard Mounting Bracket for Standard Wkstn

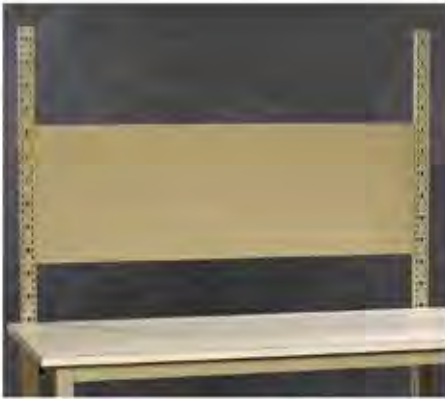

Safety Shield

FEATURES:

- All-metal Safety Shield mounts between Solid Uprights.
- Shield acts as a privacy panel and is especially useful when configuring back-to-back table installations.

ORDERING INFORMATION:

- Specify Safety Shield to match Table length.
- In-line rows: Please specify model numbers designated for starter/ending and intermediate units of in-line row.

MODEL	NUMBER	LENGTH	DESCRIPTION
3097	48"L		For stand-alone units
3098	60"L		For stand-alone units
3099	72"L		For stand-alone units
3100	48"L		For starter/ending units of in-line row
3101	48"L		For intermediate units of in-line row
3102	60"L		For starter/ending units of in-line row
3103	60"L		For intermediate units of in-line row
3104	72"L		For starter/ending units of in-line row
3105	72"L		For intermediate units of in-line row



Corkboard Panel

FEATURES:

- Formed metal frame with cork panel mounts between Solid Uprights (sold separately).
- Corkboard Panel made from quality corkboard material.

ORDERING INFORMATION:

- Order Panel length to match length of table.
- Model numbers/sizes shown are sized to fit individual, stand-alone tables only. Please consult your Design Specialist for use on in-line rows.

MODEL	HEIGHT	LENGTH
3461	12"	48"
3463	12"	60"
3465	12"	72"
3463-50	12"	half 60"
3465-50	12"	half 72"
3462	24"	48"
3464	24"	60"
3466	24"	72"
3464-50	24"	half 60"
3466-50	24"	half 72"



Magnetic Whiteboard Panel

FEATURES:

- Dual-purpose magnetic whiteboard panel useful for posting procedures, notices, checklists, etc.
- Mounts between Solid Uprights (sold separately).

ORDERING INFORMATION:

MODEL	HEIGHT	LENGTH
3450	12"	48"
3452	12"	60"
3454	12"	72"
3452-50	12"	half 60"
3454-50	12"	half 72"
3451	24"	48"
3453	24"	60"
3455	24"	72"
3453-50	24"	half 60"
3455-50	24"	half 72"



Metal Pegboard Panel

FEATURES:

- All-metal design available in full or half-length sizes.
- Mounts to Solid Uprights (sold separately).

ORDERING INFORMATION:

MODEL	HEIGHT	LENGTH
3382	12"	48"
3384	12"	60"
3386	12"	72"
3384-50	12"	half 60"
3386-50	12"	half 72"
3383	24"	48"
3385	24"	60"
3387	24"	72"
3385-50	24"	half 60"
3387-50	24"	half 72"

accessories



20-Amp Shelf (top) and Standard Shelf with Slope Option (bottom)



15-Amp Shelf (top) with Standard Shelf with Slope Option (bottom)



Cantilever Shelf Assembly

FEATURES:

- Deep style shelf of all-metal construction; flanged 2" on all sides.
- 22" deep shelf center mounts on Solid Uprights.
- Shelf may be positioned for use as a flat surface, or at an angle of up to 20 degrees at either front or back.

ORDERING INFORMATION:

- Order Shelf length to match table length. Shelf will be approx. 8" shorter than table length.
- Includes Shelf, mounting brackets, and one front/rear stop with 2" lip. Uprights must be ordered separately.
- For stand-alone tables only (will not fit on in-line row tables).

MODEL	FOR TABLE LENGTH	DESCRIPTION
3772	48"L	Approx. 40"L Shelf
3774	60"L	Approx. 52"L Shelf
3776	72"L	Approx. 64"L Shelf

Overtable/Undertable Shelf

FEATURES:

- All-metal construction; flanged 2" on all sides.
- May be used as an adjustable Overtable Shelf (requires Solid Uprights and Shelf Brackets) or as a fixed undertable Shelf (fastens to lower crossmember of open style Leg Sections).
- Prepunched to accept optional Back and End Stops.
- Shelves with 20 Amp electrics are equipped with UL®-approved 20 Amp 125 Volt duplex outlets. Shelves with 15 Amp electrics are equipped with UL®-approved 15 Amp 125 Volt duplex outlets. All shelves with electrical options are equipped with circular knockouts at each end for connection to power. Note: May be hard-wired or requires appropriate Power Cord, sold separately on page 66.

ORDERING INFORMATION:

- Overtable use: specify one pair of Shelf Brackets per Shelf.
- Undertable use: Specify one Kit-33 to mount Shelf to Leg Sections.
- Please note that undertable Shelf will not fit with Panel Leg Sections or on Cabinet Workstations. Special sizes are available on request.
- Slope Option: To set Overtable Shelf at a 20-degree slope, specify Heavy-Duty Shelf Brackets plus one Front Stop per Shelf
- Power Cords are sold separately on page 66.



Standard Shelf - Undertable position

SHELF SIZE	MODEL NUMBERS		
	STANDARD SHELF	20-AMP SHELF	15-AMP SHELF
12"D x 48"L	N3020	N3026 (2)*	3790 (2)*
12"D x 60"L	N3021	N3027 (3)	3792 (3)
12"D x 60"L Half**	N3021-50	-----	-----
12"D x 72"L	N3022	N3028 (3)	3794 (3)
12"D x 72"L Half**	N3022-50	-----	-----
18"D x 48"L	N3034	N3037 (2)	3798 (2)
18"D x 60"L	N3035	N3038 (3)	3800 (3)
18"D x 60"L Half	N3035-50	-----	-----
18"D x 72"L	N3036	N3039 (3)	3802 (3)
18"D x 72"L Half	N3036-50	-----	-----

* Indicates quantity of duplex outlets provided.

** Fits one-half of specified table length.

SHELF BRACKETS	
MODEL NUMBER	DESCRIPTION
3010-03*	12" Heavy-Duty/Slope Brackets (pair)
3011-03*	18" Heavy-Duty/Slope Brackets (pair)
3083-48	Front Stop for 48"L Shelf
3083-60	Front Stop for 60"L Shelf
3083-60-50	Front Stop for Half 60"L Shelf
3083-72	Front Stop for 72"L Shelf
3083-72-50	Front Stop for Half 72"L Shelf

* Heavy-Duty Brackets are dual-purpose. Shelf may be mounted for use as a flat shelf or as a sloped shelf.

Note: Front Stop provides 2" lip above shelf surface.



Back and End Stops

FEATURES:

- All-metal Backstop and tapered End Stops offer all-around protection.

ORDERING INFORMATION:

- Please specify Backstop length to match Table or Shelf length; Endstop length should match depth of Worksurface or Shelf.
- In-Line Rows: Order one Joining Plate to adjoin each set of abutting Backstops.
- Note: Overall height of Backstop/ Endstops is 5" before mounting. Please deduct thickness of selected worksurface (or 2" if mounted on a Shelf) to determine finished overall height.

MODEL NUMBER	DESCRIPTION
3088	48"L Backstop
3089	60"L Backstop
3089-50	For half-shelf on 60"L unit
3090	72"L Backstop
3090-50	For half-shelf on 72"L unit
3091	Backstop Joining Plate
3092	12"L End Stops (pair)
3093	18"L End Stops (pair)
3094	24"L End Stops (pair)
3095	30"L End Stops (pair)
3096	36"L End Stops (pair)



Fixed Riser Divider Shelf

Divider Shelf System

FEATURES:

- Easy-to-move snap-in dividers may be spaced at desired locations along length of Shelf in 1-1/2" increments. No fasteners required.
- Top front of Dividers and End Stops feature radius corners for appearance and safety.
- Flexible system allows for unit to be mounted in Solid Uprights for vertical height adjustability, or to be installed on Fixed Riser Panels and fastened directly to worksurface.

ORDERING INFORMATION:

- To specify a Fixed Riser Divider Shelf, please order:
One Divider Shelf Module
One pair Fixed Riser Panels
One Fixed Riser Swaybrace (or one Fixed Riser Safety Shield as shown on page 64)
- To specify an Adjustable Overtable Divider Shelf, please order:
• One Divider Shelf Module
• One pair Shelf Brackets
• Two Solid Uprights (page 68)



Adjustable Overtable Divider Shelf

- Divider Shelf Module includes:

- One perforated Shelf
- One perforated 8"H Backstop
- One pair 8"H End Stops
- Four 8"H Dividers

MODEL NUMBER	SIZE	DESCRIPTION
3633	12"D x 48"L	Divider Shelf Module
3634	12"D x 60"L	Divider Shelf Module
3635	12"D x 72"L	Divider Shelf Module
3634-50	Fits 1/2 of 60"L unit	
3635-50	Fits 1/2 of 72"L unit	
3250	12"D x 12"H*	Fixed Riser Panels
3251	12"D x 18"H*	Fixed Riser Panels
3252	12"D x 24"H*	Fixed Riser Panels
3088	48"L	Fixed Riser Swaybrace
3089	60"L	Fixed Riser Swaybrace
3090	72"L	Fixed Riser Swaybrace
3625	8"H x 12"D	Dividers (set of 4)
3010-03	12"D	Heavy-Duty Shelf Bkts (pair)

*Allow 2" clearance under Shelf

accessories

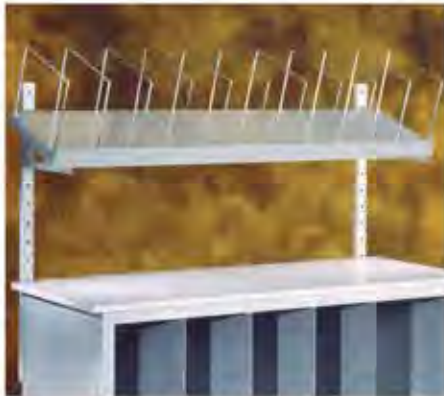

Wire Divider Shelf System

FEATURES:

- Efficient, practical way to keep larger items organized and in check. Perfect for storage of shipping containers and materials.
- Perforated shelves feature divider spacing in approximately 3" increments. Threaded metal (plated) dividers are fastened securely with nuts on underside of shelf.
- Shelves are mounted to Solid Uprights (sold separately on page 68) with the use of the Heavy Duty Shelf Brackets shown below. Shelf Brackets may also be inverted to mount Shelf at a 20° slope (as shown in photo).

ORDERING INFORMATION:

- Order one pair of Heavy-Duty Shelf Brackets for each Shelf.
- Dividers are ordered separately.
- Front Stop must be purchased if Shelf is to be installed at 20° slope.

MODEL NUMBER	DESCRIPTION
3703	12"D x 48"L Wire Divider Shelf
3704	12"D x 60"L Wire Divider Shelf
3705	12"D x 72"L Wire Divider Shelf
3713	18"D x 48"L Wire Divider Shelf
3714	18"D x 60"L Wire Divider Shelf
3715	18"D x 72"L Wire Divider Shelf
3725-12	12"D Wire Dividers (set of 4)
3725-18	18"D Wire Dividers (set of 4)
3010-03	12"D Heavy Duty/Slope Shelf Brackets (pair)
3011-03	18"D Heavy Duty/Slope Shelf Brackets (pair)
3083-48	Front Stop* for 48"L Slope Shelf
3083-60	Front Stop* for 60"L Slope Shelf
3083-72	Front Stop* for 72"L Slope Shelf

* Provides 2" height above Shelf.



Mounting Rails for Plastic Bins

FEATURES:

- Mounting Rails are fabricated of metal and accept any size bin. Bins may be hung at the front or at the rear of the rail. Rails mount to Solid Uprights, but may also be fastened within the Standard Fixed Riser Assembly with #3347 brackets.
- Options include a Slope Kit which positions rail at a 20-degree angle. on Extender Kit, which brings rail closer to operator on deeper tables.



Shown with optional Extender Kit

ORDERING INFORMATION:

- Specify Mounting Rail length to match length of table.
- For heavy loads, a third (center) Solid Upright is recommended.
- For in-line rows, please specify one #3348 Joining Bracket for each set of adjoining Mounting Rails.

MODEL NUMBER	DESCRIPTION
3342	For 48" Table
3343	For 60" Table
3343-50	For half of 60" Table
3344	For 72" Table
3344-50	For half of 72" Table
3307	Extender Kit (for 2 Uprights)
3308	Extender Kit (for 3 Uprights)
3347	Fixed Riser Mounting Kit
3348	In-Line Joining Bracket
3349	Slope Option Kit

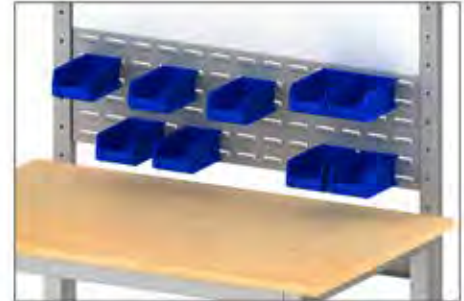

Louvered Bin Panel

FEATURES:

- All-metal construction available in full or half-length sizes.



Louvered Bin Panel Close-up

ORDERING INFORMATION:

MODEL NUMBER	LENGTH	DESCRIPTION
3471	48"L	12"H x 48"L Bin Panel
3473	60"L	12"H x 60"L Bin Panel
3473-50	60"(Half)	12"H x half-length Bin Panel
3475	72"L	12"H x 72"L Bin Panel
3475-50	72"(Half)	12"H x half-length Bin Panel



Articulating Bin Rack

FEATURES:

- Allows small parts, hardware, etc. to be positioned in most convenient location.
- Swings away from, or towards operator easily with double pivot design.

ORDERING INFORMATION:

MODEL NUMBER	DESCRIPTION
3580	Articulating Bin Rack
3590	Extra arm for additional extension capability



Shown with optional Light Transition Bracket and balancer



ORDERING INFORMATION:

- Tool balancers, air-lines, and tools not included.
- Requires Solid Uprights, sold separately on page 68.
- Order Tool Trolley System same depth and length of Table.
- 4-wheel Tool Trolleys sold separately.
- Optional Transition Bracket to accept Light Fixture: Specify Transition Bracket length to match length of Tool Trolley.
- For in-line use: Please specify one #32020 Bracket for each set of adjoining Tool Trolleys.

MODEL NUMBER	SIZE	DESCRIPTION
3425	24'D x 48'L	Tool Trolley System
3426	24'D x 60'L	Tool Trolley System
3427	24'D x 72'L	Tool Trolley System
3430	30'D x 48'L	Tool Trolley System
3431	30'D x 60'L	Tool Trolley System
3432	30'D x 72'L	Tool Trolley System
3435	36'D x 48'L	Tool Trolley System
3436	36'D x 60'L	Tool Trolley System
3437	36'D x 72'L	Tool Trolley System
3441	4-Wheel Trolley	
3445	Transition Bracket for 48'L Tool Trolley	
3446	Transition Bracket for 60'L Tool Trolley	
3447	Transition Bracket for 72'L Tool Trolley	
32020	Transition Bracket for adjoining in-line Tool Trolleys	

Tool Trolley System

FEATURES:

- Keeps tools off the worksurface, yet within easy reach. Helps eliminate tool damage due to accidental droppage.
- Adjustment features include vertical adjustment along length of Solid Uprights plus horizontal adjustment from front to rear of Table.
- Four-wheel trolleys sold separately. Optional Transition Bracket allows Light Fixture (sold separately) to be mounted to the Tool Trolley system.



Paper Roll Holder/Cutter

FEATURES:

- Fits half-length of 72" unit only.
- All-steel holder/cutter mounts to Solid Uprights.
- Equipped with floating tear-off cutter of heavy guage steel.
- Holds one roll of paper having a 1" core, up to 30" wide.

ORDERING INFORMATION:

- Requires at least two Solid Uprights plus Center Standard Mounting Bracket (sold separately—see p. 68) for installation.

MODEL NUMBER	DESCRIPTION
3786-50	Paper Roll Holder/Cutter for one-half of 72'L unit



Wirespool Holder

FEATURES:

- Keeps wire and other spooled materials organized and within arm's reach.

ORDERING INFORMATION:

- Requires Solid Uprights, sold separately on page 68.
- Full-Length Rods for tables over 48"L require 3 Solid Uprights.
- Call for assistance with in-line row use.
- Wirespool Holder includes 3/4" diameter rod (painted) and 2 (or 3) mounting brackets.

MODEL NUMBER	LENGTH	DESCRIPTION
3047-01	48"	Full-Length Rod
3048-01	60"	Full-Length Rod
3048-50	60"	Half-Length Rod
3049-01	72"	Full-Length Rod
3049-50	72"	Half-Length Rod



Articulating Tray

FEATURES:

- Keeps tools, parts, and equipment off the worksurface, yet within easy reach.
- Tray is 18"L x 12"D with 1" flange around all sides of worksurface and includes a foam pad insert.

ORDERING INFORMATION:

MODEL NUMBER	DESCRIPTION
3595	Articulating Bin Rack
3590	Extra arm for additional extension capability

accessories



Rubber Bumpers

FEATURES:

- Heavy-duty Rubber Bumpers are highly recommended on mobile units to protect worksurface corners, walls, and other objects that mobile unit may come into contact with during travel.

ORDERING INFORMATION:

- Rubber Bumpers are sold individually.
- Rubber Bumpers may not be installed at rear corners of any table equipped with Solid Uprights, on front corners of post-formed tops, or on epoxy resin tops.
- Installation of Rubber Bumper requires drilling into worksurface.

MODEL NUMBER	DESCRIPTION
3140-B	Black Heavy-Duty Rubber Bumper



Rubber Boots

FEATURES:

- Boot slips over base of Leg Section to enhance table appearance.
- Floor cleaning is made easier by eliminating the need to clean around leg levellers. Base of boot is open to eliminate interference with leveling function.

ORDERING INFORMATION:

- May be specified for use on Standard, Heavy-Duty, or Corner Workstation Leg Sections.
- Boots are sold individually. Please order two per Leg Section.

MODEL NUMBER	DESCRIPTION
1017	Rubber Boot



Hanging Waste Container

FEATURES:

- Heavy-duty plastic construction for easy cleaning.
- Keeps container off floor surface for ease of floor maintenance.
- Container is 11-5/8"L x 8-1/4"W x 12-1/2"H

ORDERING INFORMATION:

- May be specified for use on Tables equipped with open style Heavy-Duty Leg Sections.
- May be hung from outside or inside of Leg Section.
- Wastebasket available in beige color only.

MODEL NUMBER	DESCRIPTION
3130	Hanging Waste Container



Mini Corner Guards

- Suitable for use on metal worksurface corners, and will fit many items, such as Undertable Shelves, worksurfaces, drawer cases, etc.
- Adhesive mounting material NOT included.

ORDERING INFORMATION:

- 2-1/4" X 2-1/4"

MODEL NUMBER	DESCRIPTION
3140-M-4	Mini Corner Guard 4-Pack
3140-M-12	Mini Corner Guard 12-Pack



Leg Levellers

FEATURES:

- Provide 3/4" + or - of vertical levelling adjustment. Levellers are equipped with a 1/2" x 13 x 2-1/2" thread.

- Standard Leg Levellers are provided with all Workplace® Leg Sections.
- Vibration-Absorbing Leg Levellers are equipped with extra-thick waffled base pad to help reduce effects of vibration.
- Lag-To-Floor Levellers feature a rectangular metal base plate with pre-drilled holes to allow table to be bolted to floor.

ORDERING INFORMATION:

- Leg Levellers sold individually. Please order two per Leg Section.

MODEL NUMBER	DESCRIPTION
1143	Standard Leveller
1144	Vibration-Absorbing Leveller
1145	Lag-To-Floor Leveller



Document Holder

FEATURES:

- Positions documents in the most convenient location. Swivels away from or towards operator easily with double pivot design. Spacious 11 x 17 holder is equipped with two spring clips.
- Mounts to Solid Upright (sold separately).

ORDERING INFORMATION:

MODEL NUMBER	DESCRIPTION
3585	Document Holder Articulating Arm
3590	Extra arm for additional extension capability

example configurations

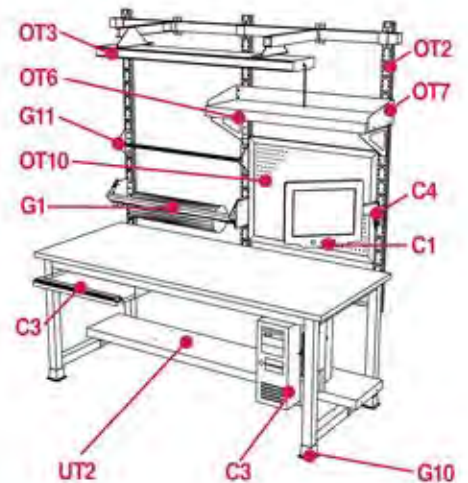
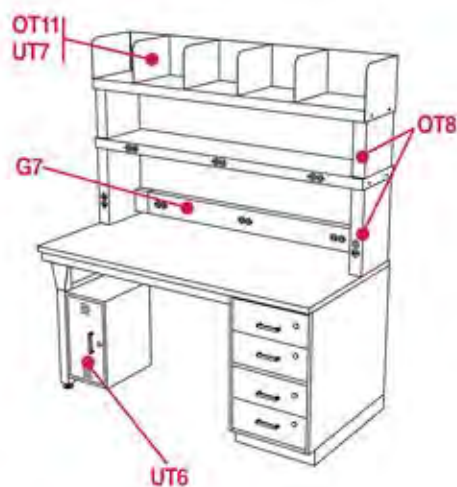
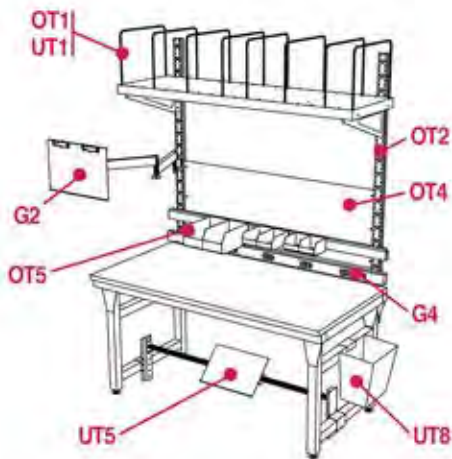

OVERTABLE ACCESSORIES

OT1 Wire Divider Shelf System <i>p.72</i>	OT2 Solid Uprights <i>p.68</i>	OT3 Light Suspension System <i>p.67</i>	OT4 Safety Shield <i>p.69</i>
OT5 Bin Rail <i>p.72</i>	OT6 Overtable Shelf <i>p.70</i>	OT7 Back & End Stops <i>p.71</i>	OT8 Panel Riser Shelf <i>p.63</i>
OT9 Tool Trolley System <i>p.73</i>	OT10 Pegboard/Corkboards <i>p.69</i>	OT11 Divider Shelf System <i>p.71</i>	OT12 Cantilever Shelf <i>p.70</i>

UNDERTABLE ACCESSORIES

UT1 Wire Divider Shelf System <i>p.72</i>	UT2 Undertable Shelf <i>p.70</i>	UT3 Storage Drawers <i>p.60</i>	UT4 Standard Footrest <i>p.68</i>
UT5 Multi-Adjust Footrest <i>p.68</i>	UT6 Personal Locker <i>p.61</i>	UT7 Divider Shelf System <i>p.71</i>	UT8 Hanging Waste Container <i>p.74</i>

COMPUTER-RELATED ACCESSORIES

C1 Articulating Monitor Arms <i>p.62</i>	C2 CPU Caddy <i>p.63</i>	C3 Keyboard Tray <i>p.63</i>	C4 Laptop Tray <i>p.62</i>
---	---------------------------------	-------------------------------------	-----------------------------------

GENERAL ACCESSORIES

G1 Paper Roll Cutter/Holder <i>p.73</i>	G2 Document Holder <i>p.74</i>	G3 Lamp Bracket <i>p.67</i>	G4 15/20 Amp Powerstrip <i>p.65</i>
G5 Airtrough <i>p.66</i>	G6 Rubber Bumpers Mini Corner Guards <i>p.74</i>	G7 20-amp Powertrough <i>p.65</i>	G8 Articulating Bin Rack <i>p.72</i>
G9 Leg Levelers <i>p.74</i>	G10 Rubber Boots <i>p.74</i>	G11 Spool Holder <i>p.73</i>	G12 Articulating Tray <i>p.73</i>

NOTE: This table is NOT a complete listing of all available accessories shown on pages 60 - 74.

These are just a few examples illustrating how Workplace® workstations may be custom configured using the wide array of available Add-On Accessories shown on pages 60 to 74.

workplace workplace workplace workplace
lace workplace workplace workplace wor
kplace workplace workplace workplace w
workplace workplace workplace workplace
lace workplace workplace workplace wor



Durable

Solid welded tubeframe construction, heavy duty bracing, and worksurfaces that take abuse ensure every Workplace product outlasts even the toughest applications.



Ergonomic

Whether it's manually or motorized height-adjustable, correct ergonomics is the number one design objective of every Workplace product we build.



Mobile

Ever-changing task requirements demand wheeled mobility. Every workstation model we build may be made mobile without compromising its strength or load capacity .



Configurable

Workplace products work together in a virtually infinite variety of ways. Why be constrained to the limitations of a catalog when a perfect solution can be configured to order?



Versatile

Choose from a wide range of accessories to maximize productivity: lighting, footrests, tool holders, shelving, power, and computer peripherals. Just to name a few.

workplace workplace workplace workplace
lace workplace workplace workplace wor

workplace[®]

MODULAR SYSTEMS

...Experience matters.™

Workplace Modular Systems LLC

562 Mammoth Road
Londonderry, NH 03053-2117

Phone: 800.258.9700

Web: workplacenh.com

Email: info@workplacenh.com

© 2016 Workplace Modular Systems LLC
Printed in USA